

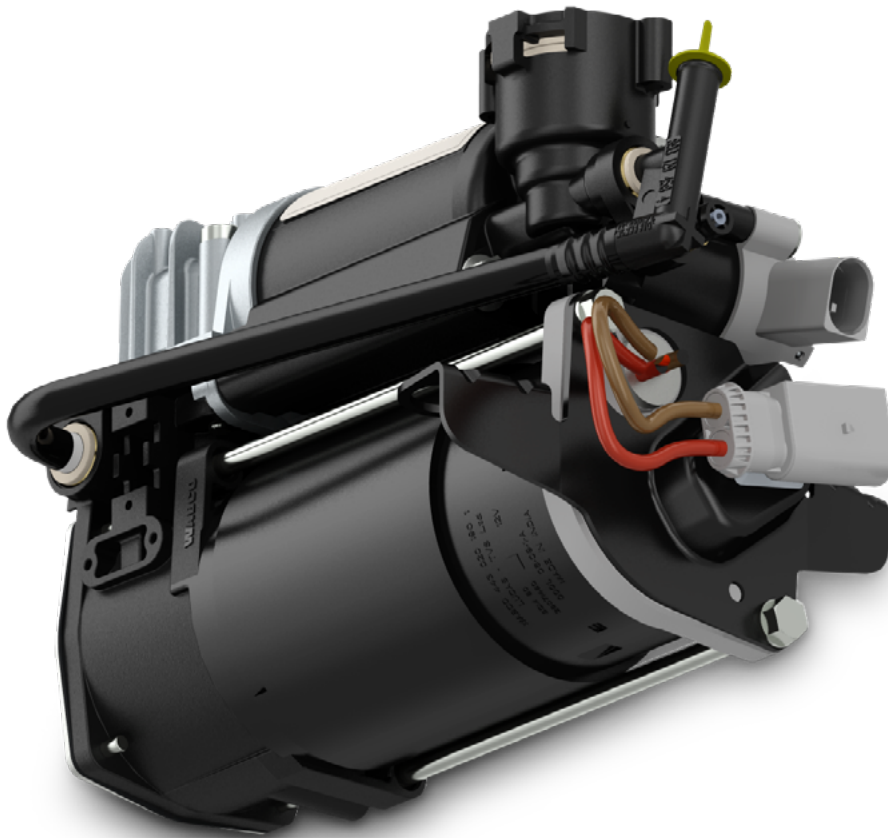

# Core Acceptance Criteria

Air Suspension Compressors for WABCO applications



AFTERMARKET

# General information

## Accepted

- Core must be in an off-vehicle condition.
- Core must meet acceptance standards established within this document.
- The core must not be cracked, broken or deformed.
- The body must not be strongly corroded or burnt (structure stability disturbance).
- The core must be complete and not disassembled.

## Rejected

- The core is a not complete unit and disassembled or altered in any manner.
- The core is damaged by non-operational causes such as car crash damage, rough handling, fire or improper removal, crack, stuff losses.
- There has been prior attempt at rebuilding the component.

# Acceptance criteria

Accepted 



Damaged plug (wires)

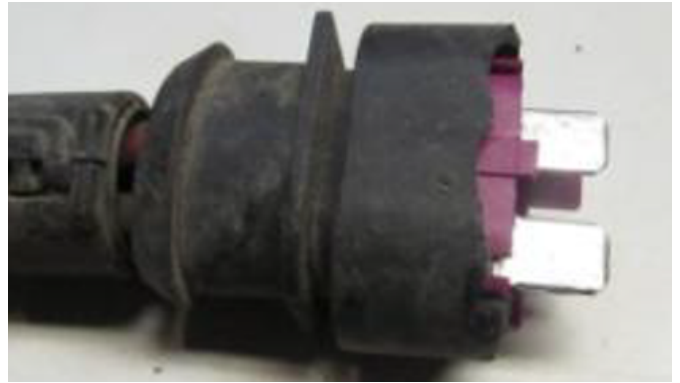

Damaged plug (wires)



Missing plug



Damaged plug (valve)



Corroded screws



Cut or damaged cables

# Acceptance criteria

Accepted ✓



Damaged plastic parts

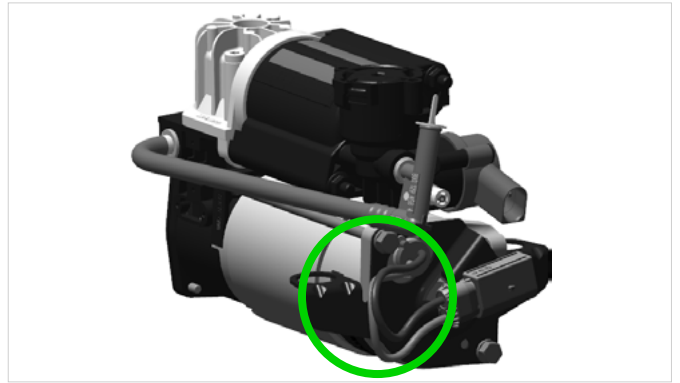

Allowed area cut of cables

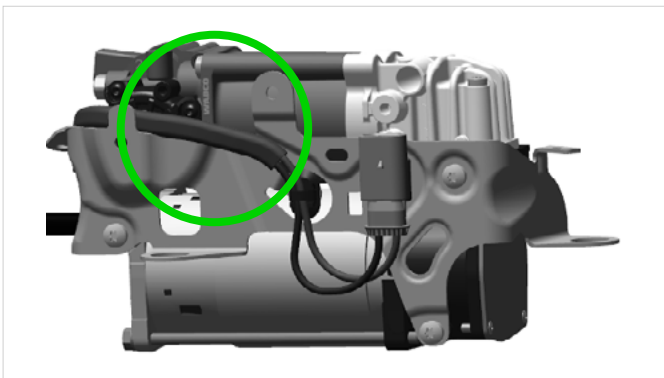

Allowed area cut of cables

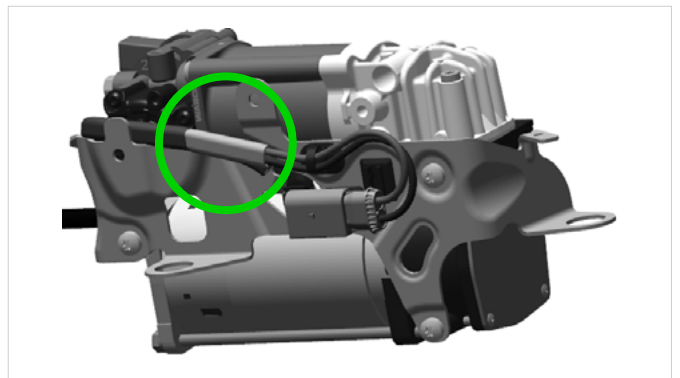

Allowed area cut of cables

# Acceptance criteria

Rejected (X)



Device is dismantled



Device is dismantled



Missing screws

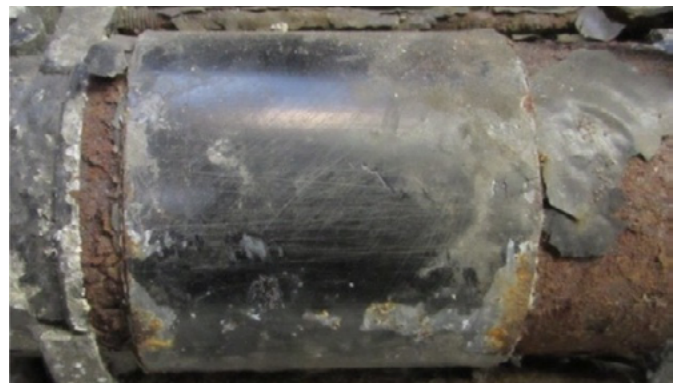

Heavy corrosion(Not off-vehicle condition)



Missing components

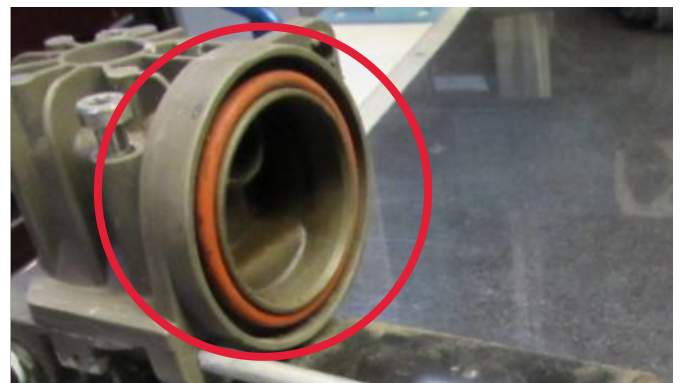

Missing components

# Acceptance criteria

## Rejected



Missing components



Missing components. Corrosion inside.



Reassembled device



Reassembled device

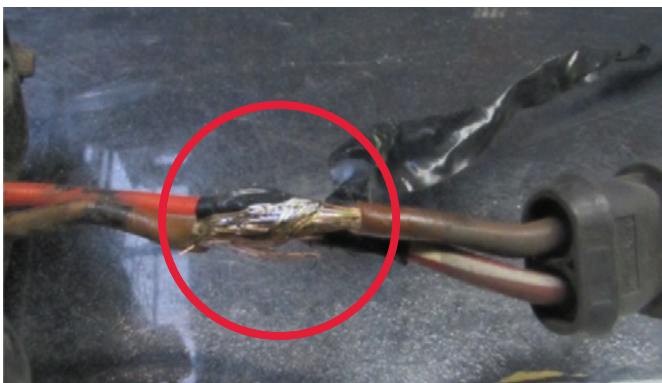

Cables shorter than 2 cm.  
Cables / wires damaged closer than 2 cm from housing.



Cables shorter than 2 cm.  
Cables / wires damaged closer than 2 cm from housing.

# Acceptance criteria

Rejected 

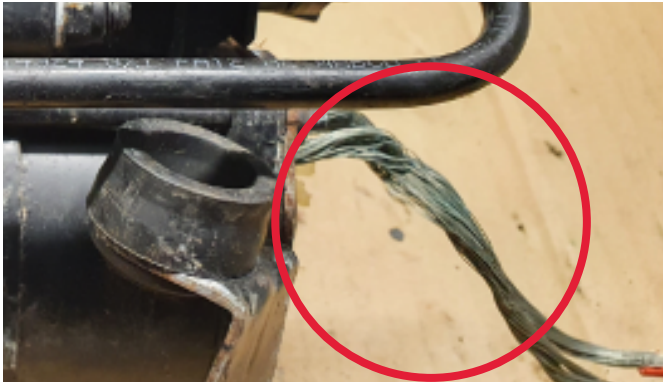

No cable cover

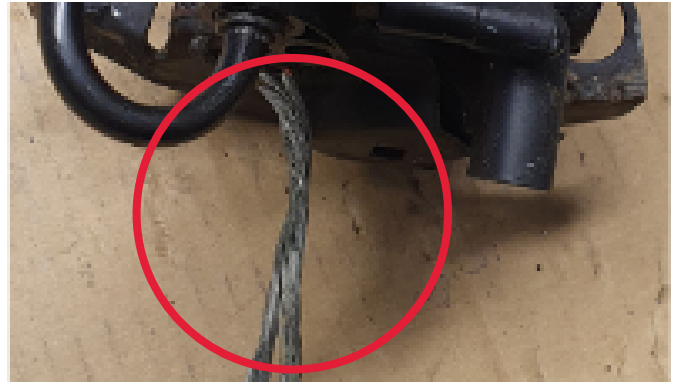

No cable cover



Damaged or broken device



Damaged or broken device



Damaged or broken device



Damaged device

## ZF Group

ZF CV Systems Poland Sp. z o.o.  
ul. Logistyczna 2,  
55-020 Zorawina (Krajków), Poland

[aftermarket.zf.com](http://aftermarket.zf.com)



[instagram.com/zfaftermarket](https://www.instagram.com/zfaftermarket)  
[facebook.com/zfaftermarket.global](https://www.facebook.com/zfaftermarket.global)  
[youtube.com/@ZFAftermarket](https://www.youtube.com/@ZFAftermarket)  
[linkedin.com/showcase/zfaftermarket](https://www.linkedin.com/showcase/zfaftermarket)